

MORE THAN  
**50+**  
YEARS

**CAME** 



# MTM A CONNECT

**4G**



**ALWAYS CONNECTED  
TO YOUR HOME**

[CAME.COM](https://www.came.com)

# MTM A CONNECT



















Answer intercom calls and open your gate or door directly from your phone, no receiver required.

MTM A CONNECT employs a 4G LTE SIM card for wireless mobile connection to services and data.

The perfect solution for small to medium applications, and because of its simplicity, strength and reliability it is also suitable for larger accommodation.

MTM A CONNECT is the first audio entry module in the MTM series that requires only a power supply and no additional wiring.

	MTM GSM	MTMA CONNECT
<b>MAIN FEATURES</b>		
Network	2G	
Communication	GSM	VoLTE
Programming	SMS	App
Users	1,000	3,000
CAME CONNECT Compatible		
Call Forwarding		
Timed Call Forwarding		
Calls Per Button	5	5
Built-in Real Time Clock		
Named Address Book		
Voicemail Avoidance		
Power Requirements	VAS/101	VAS/101 or Powered directly from CAME Automation
Dial to Open		
End User App		

# CONNECT DIRECTLY TO A CAME CONTROL PANEL

## ACTIVATE TWO AUTOMATIONS FROM THE HANDSET

By connecting MTMA CONNECT directly to a CAME control panel it is possible to activate two automations at the same time, eg a driveway gate for vehicles and a pedestrian gate.

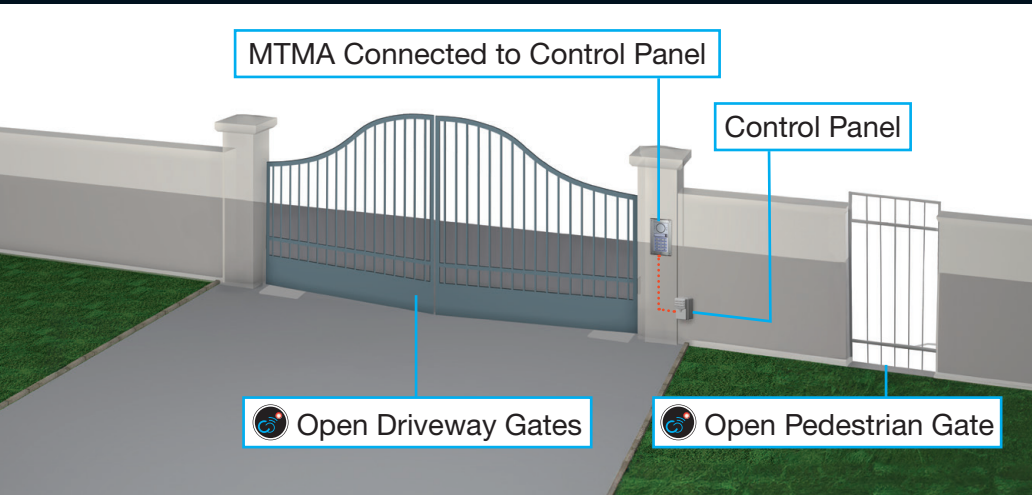

## POWER THE MTMA CONNECT DIRECTLY FROM THE CONTROL PANEL

MTMA CONNECT is able to take power from the control panel, meaning that no additional power supply unit is required.

## NO NEED FOR EXTRA CABLING

MTMA CONNECT communicates directly with CAME automation, meaning there is no need for additional ground work and cabling.



## THE LATEST CUTTING-EDGE VoLTE TECHNOLOGY

VoLTE stands for Voice over Long-Term Evolution or Voice over LTE. VoLTE offers the possibility to voice call via the LTE/4G mobile network.

Previously, 4G was limited to data only. When it came to calls, your device would automatically switch to 3G or 2G. As this switching took place there would be a few seconds of delay before the call connected. Thanks to VoLTE, that delay is gone.

What are the benefits of VoLTE Calling.

- » Fast call connection
- » High voice quality
- » Reduced background noise
- » When making a VoLTE call, the network provider counts the call as voice minutes. Meaning you pay for the voice call service, not the data you use.

# FAST, SIMPLE SETUP

## CONFIGURE AND COMMISSION THE MTM A ALONGSIDE YOUR AUTOMATION

Simplify the setup and management of your MTM A Connect intercom with the CAME SETUP App. Programme where the device calls, phone numbers and key codes to allow access, manage the address book and more all within the App.

When installing the MTM A Connect alongside CAME automation, you can set both up using the CAME Setup App, simplifying further the commissioning of both systems.

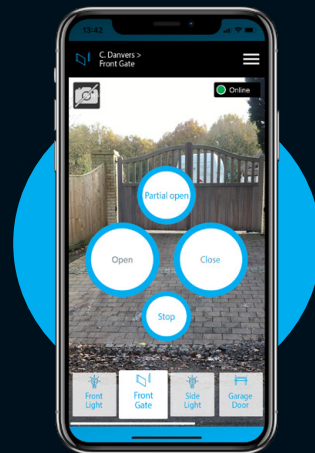

# GO FULLY CONNECTED WITH CAME CONNECT

## MANAGE, TROUBLESHOOT AND MAINTAIN REMOTELY

With a built in CAME CONNECT Gateway, the CAME CONNECT SetUp App offers even more control. Access to advanced features such as editing, adding or deleting phone numbers remotely from anywhere you're working.

## CAME CONNECT WEB PORTAL

The perfect connected off site partner for every CAME installer, the web portal offers advanced features to the installer including:

- » Can be managed by any staff members thanks to intuitive interface.
- » Create an action list of custom scenarios.
- » Create access control systems including granting user access.
- » Manage site mapping.
- » Manage all of your support requests.
- » Add a powerful maintenance calendar.
- » Manage a site exclusion schedule.



# ADVANTAGES FOR THE END USER

With MTMA Connect and the CAME apps, users can:

- AUTOMATION APP** Unlock gates and open automation
- CONNECT SETUP APP** Share the CAME Automation App with family
- CONNECT SETUP APP** Manage user access
- CONNECT SETUP APP** Change PIN codes
- CONNECT SETUP APP** Create and edit schedules



## CONNECT SetUp App

## Automation App

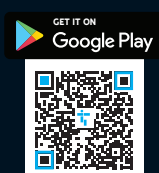
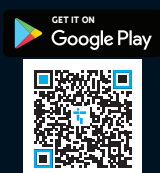

## PROGRAMMABLE TIME PROFILES

Powerful time profiles within the MTM A Connect offer the user flexible options for calling different numbers at different times of the day. For example, during working hours the intercom could call a number in a garden office first, before the house phone, then mobiles. In the evening this could change to calling the house first removing the garden office altogether.



## ACTIVATE ADDITIONAL DEVICES

With two additional output relays, the MTM A Connect can activate more than automation. Activate lighting or turn on an irrigation system by dialling into the intercom or with preprogrammed keycodes. For ultimate convenience, customers with the CAME Automation App can also activate these additional devices with a tap of their phone.



## DUAL FUNCTION ACTIVATION

Providing customers with even more convenience, the MTM A Connect can be programmed to activate multiple devices on a single command. Dial in to open the entrance gates and a garage door with one instruction for a simple, frictionless experience for the user.



## FLEXIBLE ACCESS SCENARIOS

The MTM A Connect has a real time clock on-board with automatic daylight savings. This facilitates a powerful suite of access scenarios. Programme the entrance to allow access to a gardener at set times and days each week or allow free access for the post to be delivered each morning. Limit operation from inbound calls according to a calendar to prevent or enable access to users depending on specific demands.



## COMPREHENSIVE EVENT LOG

For maintenance purposes, the MTM A Connect hosts an event log history of 10,000 records. Using this log, you can identify any issues with the intercom and automation system. You can review the log to diagnose problems and perform troubleshooting remotely and efficiently.



# MTM A **CONNECT** 4G

CAME.COM

## INTEGRATES FLAWLESSLY WITH THE FULL MTM SYSTEM

Available as a stand-alone, ready to fit kit, the MTM A CONNECT can also be incorporated in the MTM modular system.

### DIMENSIONS

Recess-mounted 13mm thickness  
(16mm MTM VR version)  
Wall-mounted 64mm thickness



**ALUMINIUM  
VERSION**



**IK09 CERTIFIED  
VANDAL-PROOF VERSION**



**IK09 CERTIFIED  
VANDAL-PROOF STAINLESS  
STEEL VERSION**



Call in progress  
LED

Loudspeaker

Conversation in  
progress LED

User busy  
LED

Door open  
LED



CAME

Keypad

scale 1:1

# MTM & MTM VR

THE RANGE OF EXTERNAL MODULAR ENTRY PANELS



MTM A CONNECT is fully compatible with an extensive range of modular configurations, which work with five different systems, allowing multiple functions to be carried out.

It's clean design has strong aesthetic appeal in all installation scenarios, while maintaining simple functionality.

Particular attention to detail has been paid to the finish, by eliminating the speaker holes, backlighting the keypad to give it a sleek look, and using satin aluminium for durability.



**Flush mount installation**

Thickness 13 mm



**Surface mount installation**

Thickness 64 mm



**Water and dust protection rating**

IP54



**Impact resistance rating of MTM**

IK07



**Induction loop version available by request**

T



**Impact resistance rating of MTM VR**

IK09

## FEATURES

MTM: Anodised and frosted natural aluminium finish

MTM VR: Die cast Zamak metal composite construction

Unique design without typical speaker holes

Acoustic and visual signals

Backlighting of blue or white label holders with intensity adjustment

Up to 98 call buttons and unlimited digital calls

## DIMENSIONS

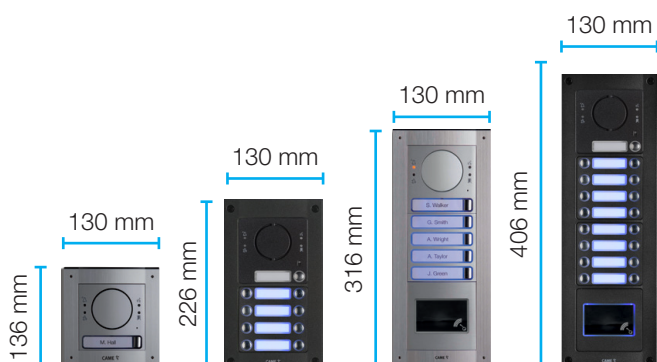





### DIGITAL COMPOSITION

The digital display allows a phone book with up to 3000 names to be displayed. During the programming phase you can choose the most appropriate search mode based on the number of users, a scrolling list or an alphabetical block search.



### PUSH-BUTTON COMPOSITIONS

On the call module, you can customise the amount of buttons required. Using a variety of modular front plates you can achieve maximum button composition flexibility. Available with 2, 3, 4 and 8 button front plates.



### ACCESS CONTROL

The MTM range also includes 2 modules dedicated to access control, one with a keypad and one with an RFID reader. Both modules are equipped with 2 on-board relays and 2 inputs for direct relay activation.

#### RECESS MOUNTING BOX

Available for the various versions of external unit, from 1 to 4 modules, depth of 48 mm.

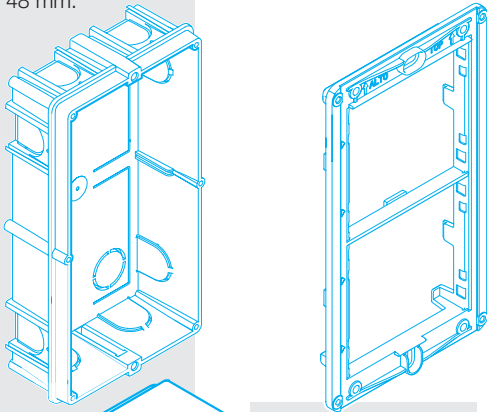

#### FRAME

Aluminium module frame with cathodolysis finish and black paint to ensure high resistance to corrosion and rust. Compatible with the built-in boxes of BTicino, Comelit and Urmet.

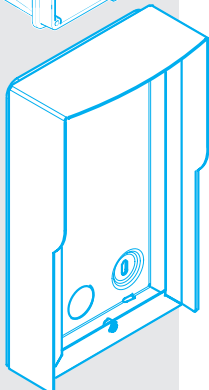

#### RAIN HOOD

Wall box available in cases where recessed installation is not possible.

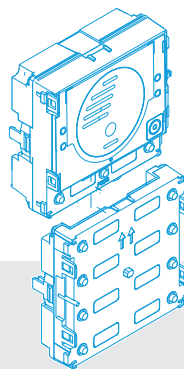

#### ELECTRONIC MODULES

Snap-in installation without the use of screws. Simple and error-free wiring between modules thanks to polarized connectors.

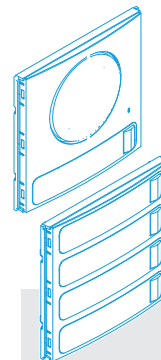

#### FRONT PLATE

Front panels ready to use, pre-configured without the need to manage additional buttons and plugs. External face is satinised aluminium solid structure rated to IK07 resistance. A VR version is also available in a Zamak finish rated IK09.

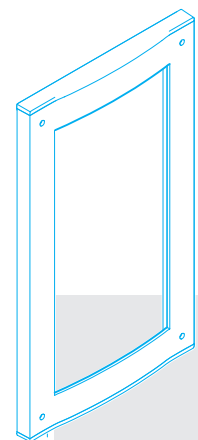

#### EXTERNAL FRAME

Closing frame with a clean line, entirely in satin aluminium.

### INSTALLING MTM IS FAST AND EASY

There are 5 components that make up the external unit: the wall or recessed box, the frame, the electronic module, the front plate and the external frame.

# VRW & VRM

MODULAR EXTERNAL UNIT WITH UK MANUFACTURED VANDAL RESISTANT FACIAS



A key feature of VRW and VRM is the durability and strength of the materials. It uses the same electronic modules and easy to fit functionality as the standard MTM however, it uses an IK09 rated vandal resistant marine grade stainless steel manufactured in the UK.

Additionally, VRM uses IK09 rated buttons manufactured in Italy.

Vandal resistant entry panels are available in a number of finishes such as Stainless Steel, Highly Polished Steel, Brass and can be custom powder coated in any RAL colour of your choice.



**Flush mount installation**

Thickness 2 mm



**Surface mount installation**

Thickness 52 mm



**Water and dust protection rating**

IP65



**Impact resistance rating**

IK09



**Induction loop version available by request**



**Marine grade 316 stainless steel**

## FEATURES (In addition to the benefits of the MTM VR)

Bespoke finishes

Laser engraving

IP65 rated bespoke buttons

Manufactured in the UK

Impact & water resistant

Custom sizes

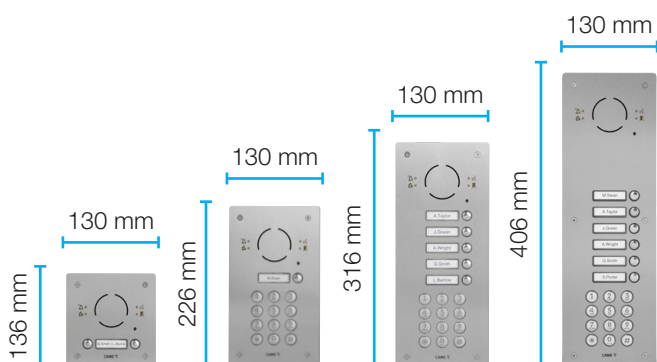

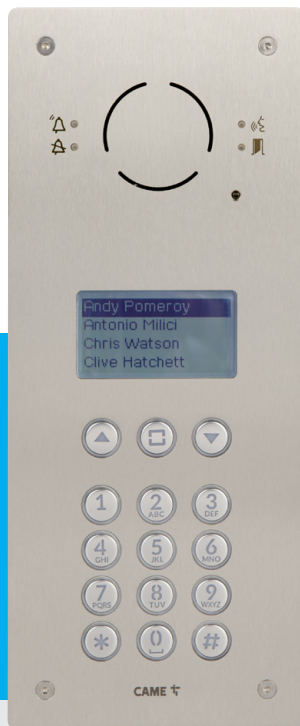

### DIGITAL COMPOSITION

The digital display allows a phone book with up to 3000 names to be displayed. During the programming phase you can choose the most appropriate search mode based on the number of users: a scrolling list or an alphabetical block search.

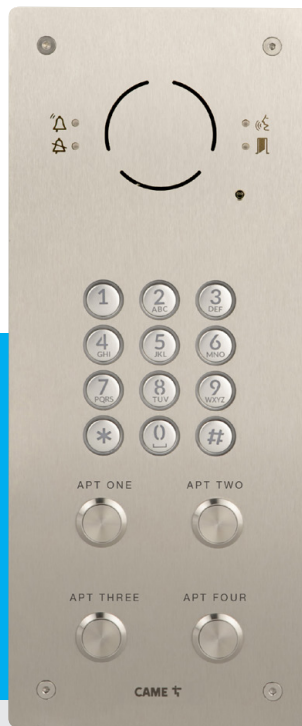

### PUSH-BUTTON COMPOSITIONS

On the call module, you can customise the amount of buttons required. Using a variety of modular front plates you can achieve maximum button composition flexibility. Available with 2, 3, 4, 5 and 8 button front plates.



### ACCESS CONTROL

The VRW & VRM ranges can accommodate the MTM VR keypad unit for standalone access control as well as the unique 'Universal reader bracket' able to house most types of common proximity access control reader.



### VANDAL RESISTANT

The vandal resistant entry panel is constructed from marine grade 316 brushed stainless steel and manufactured in the UK to the highest standards. The IP65 rated crush proof buttons can be used with coded keypads, proximity reader cut outs or smash and scratch resistant windows which are constructed from Makralon.

Surface or flush mounted, they are the last word in hard wearing, durable entry panel design. As well as the standard range, custom sizes can also be manufactured to suit any application.

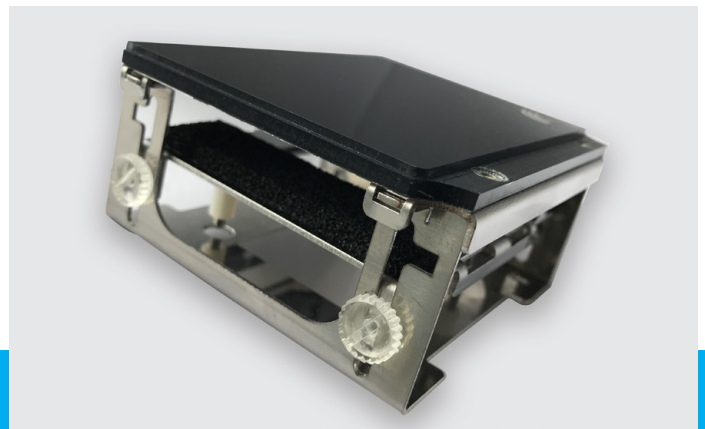

### UNIVERSAL READER BRACKET

VRW and VRM confirm their versatility with the introduction of our new universal proximity reader bracket system. A simple, innovative component utilising precision engineering to deliver a product with a wealth of options for our customers. Manufactured to exacting standards, our versatile bracket allows you to use almost any proximity reader in the market.

Unique to our vandal resistant range, you can order your entry panels safe in the knowledge that VRW and VRM will accommodate it without the need for further components.

# VRC BESPOKE

CUSTOM MADE MODULAR EXTERNAL UNIT WITH FULL CUSTOMISATION OPTIONS

4G



Flush mount installation  
Thickness 2 mm



Water and dust protection rating



Induction loop version available by request



Surface mount installation  
Thickness 52 mm



Impact resistance rating



Marine grade 316 stainless steel

## DIMENSIONS

Our bespoke VRM panels are made to order. Therefore we can manufacture them to any size and specification, please contact us to discuss your requirements.

Our VRM bespoke range combines the durability, strength and modularity found in our standard VRM range, but with complete versatility and customisation options available.

Whatever the desire of your customer, we can provide a panel solution that meets their requirements. VRM bespoke allows you to create an entry panel that is custom built to your specifications whatever the size, shape, colour or finish you desire.

Our high precision laser engraving option enables us to complete our bespoke service so you can completely customise your panel with company logos and specific font styles and sizes.

## FEATURES (In addition to the benefits of the MTM VR)

Bespoke finishes

Laser engraving

Unmatched video quality

IP65 rated bespoke buttons

Manufactured in the UK

Impact & water resistant

Custom sizes

## BESPOKE ENGRAVING

Panels are finished with high precision laser engraving. This can be tailored to any requirement including the addition of company or client logos or any specific font styles and sizes.

Laser engraving provides hard wearing, high contrast text and graphics to an exceptional level of detail.

For a more traditional finish, etched engraving can also be provided. Whilst not achieving the level of detail provided by laser engraving, for clients requiring a more classic look, or a particular colour of text, this option can be used.

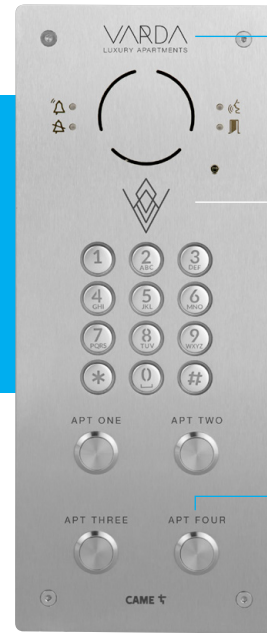
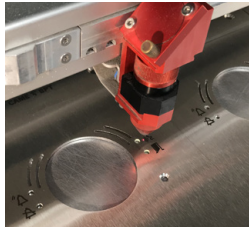

Your company name engraved here

Your company logo engraved here

Individually label each call button

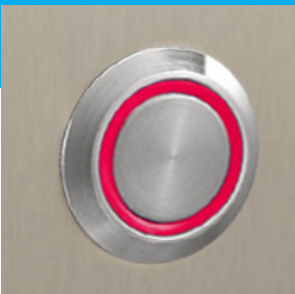

## BESPOKE BUTTONS

To complement your entry panel there are a vast array of push button styles.

Various illumination colours as well as brass, black, bronze and polished finishes are all available to suit any requirement. In addition, a range of DDA buttons with braille and tactile markings can also be included in any panel design.

With the use of LED's we can offer a whole host of lighting colours for the illumination of your buttons.

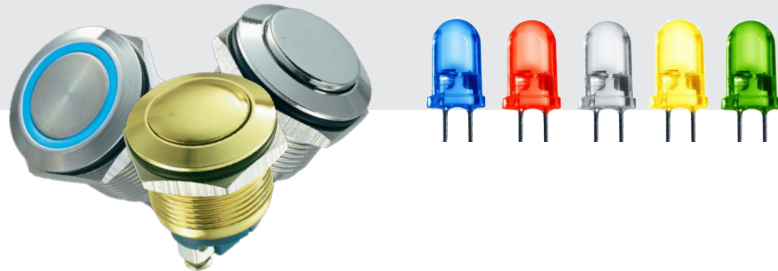

## UNIQUE FINISHES

As well as the standard brushed stainless steel, satin black, highly polished and classic brass options available throughout the range, entry panels can be finished to suit the most exacting requirements. From high resistant powder coating in a vast range of RAL finishes to antique bronze and metal effect coatings, anything is possible.

The range of finishes is vast so please call us with your most specific requirements.



# MTM A **4G** CONNECT

## DEMONSTRATION KITS



**ALUMINIUM  
VERSION**



**IK09 CERTIFIED  
VANDAL-PROOF VERSION**



### DEMONSTRATION KITS SUPPLIED WITH:

- » Painted metal stand (can be engraved with your logo)
- » Flush mounted MTM panel with keypad (standard/Zamak options)
- » VAS/101 PSU
- » 2m cable and plug
- » Aerial and magnetic base
- » CAME Key plus adapter

**CONTACT US TO ORDER YOURS NOW...**  
**01442 230 800**

# 4G AUDIO KITS

## 16 MTM CONNECT 4G Kits

- 16 MTM CONNECT 4G Standard
- 17 MTM CONNECT 4G VR Zamak
- 18 MTM CONNECT 4G Standard with Keypad
- 19 MTM CONNECT 4G VR Zamak with Keypad
- 20 MTM CONNECT 4G Standard with Proximity Reader Housing
- 21 MTM CONNECT 4G VR Zamak with Proximity Reader Housing

## 22 VRW CONNECT 4G Kits

- 22 VRW CONNECT 4G
- 23 VRW CONNECT 4G with Keypad
- 24 VRW CONNECT 4G with Proximity Reader Housing

## 25 VRM CONNECT 4G Kits

- 25 VRM CONNECT 4G
- 26 VRM CONNECT 4G with Keypad
- 27 VRM CONNECT 4G with Proximity Reader Housing

## 28 Dimensions

- 28 MTM Dimensions
- 30 VRW Dimensions
- 32 VRM Dimensions

List Prices shown in this price list are displayed in (£) for UK and (€) for Ireland. All prices are exclusive of VAT. E&OE.

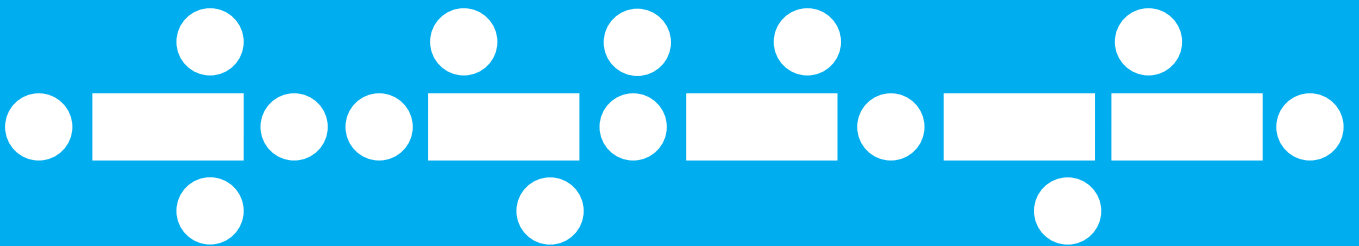

# 4G MTM 4G STANDARD ENTRY PANEL

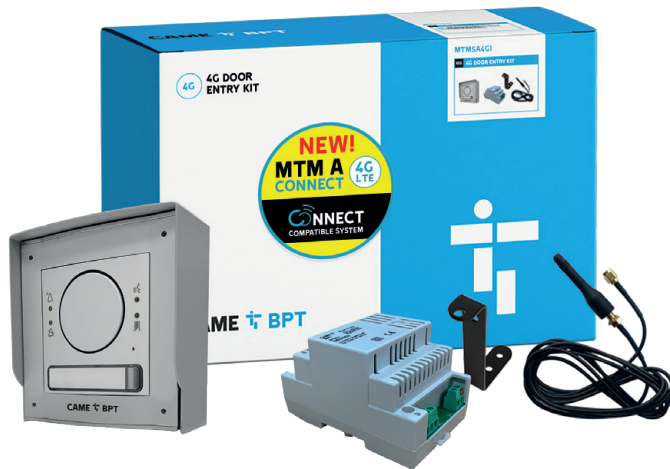

Surface kit shown - includes rainshield

## CONTENTS

- Audio module for 4G System
- Front piece for module with one to ten buttons
- Frame with one- or two-module profile
- Control module and optional power supply
- Antenna



## SURFACE MOUNTED PANEL KITS

Buttons/Way	Modules	With PSU Kit Code	List Price	Without PSU Kit Code	List Price
1 WAY	1	MTMSA4G1	734.00	MTMSA4G1NP	639.60
2 WAY		MTMSA4G2D	738.00	MTMSA4G2DNP	643.60
5 WAY	2	MTMSA4G5	816.00	MTMSA4G5NP	721.60
10 WAY		MTMSA4G10D	822.00	MTMSA4G10DNP	727.60
DIGITAL*	3	MTMSKDA4G	1,041.00	MTMSKDA4GNP	946.60

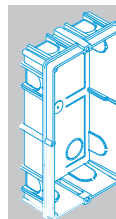

**FLUSH KITS**  
Include back box.

## FLUSH MOUNTED PANEL KITS

Buttons/Way	Modules	With PSU Kit Code	List Price	Without PSU Kit Code	List Price
1 WAY	1	MTMFA4G1	678.00	MTMFA4G1NP	583.60
2 WAY		MTMFA4G2D	682.00	MTMFA4G2DNP	587.60
5 WAY	2	MTMFA4G5	752.00	MTMFA4G5NP	657.60
10 WAY		MTMFA4G10D	758.00	MTMFA4G10DNP	663.60
DIGITAL*	3	MTMFKDA4G	966.00	MTMFKDA4GNP	871.60

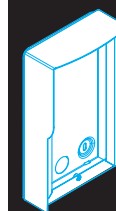

**SURFACE KITS**  
Include rainshield.

### \*DIGITAL VERSION



See page 8 for MTM overview.



See page 28 for MTM dimensions.

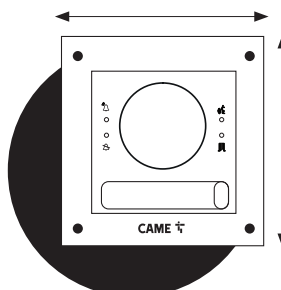





# 4G MTM 4G VR ZAMAK

## ENTRY PANEL



Surface kit shown - includes rainshield

## CONTENTS

- Audio module for 4G System
- Front piece for module with one to ten buttons
- Frame with one- or two-module profile
- Control module and optional power supply
- Antenna



## SURFACE MOUNTED PANEL KITS

Buttons/Way	Modules	With PSU Kit Code	List Price	Without PSU Kit Code	List Price
1 WAY	1	MTMSVRA4G1	822.00	MTMSVRA4G1NP	727.60
2 WAY		MTMSVRA4G2D	825.00	MTMSVRA4G2DNP	730.60
5 WAY	2	MTMSVRA4G5	945.00	MTMSVRA4G5NP	850.60
10 WAY		MTMSVRA4G10D	954.00	MTMSVRA4G10DNP	859.60
DIGITAL*	3	MTMSVRKDA4G	1,193.00	MTMSVRKDA4GNP	1,098.60

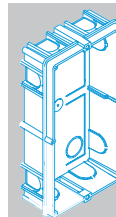

**FLUSH KITS**  
Include back box.

## FLUSH MOUNTED PANEL KITS

Buttons/Way	Modules	With PSU Kit Code	List Price	Without PSU Kit Code	List Price
1 WAY	1	MTMFVRA4G1	767.00	MTMFVRA4G1NP	672.60
2 WAY		MTMFVRA4G2D	771.00	MTMFVRA4G2DNP	676.60
5 WAY	2	MTMFVRA4G5	880.00	MTMFVRA4G5NP	785.60
10 WAY		MTMFVRA4G10D	890.00	MTMFVRA4G10DNP	795.60
DIGITAL*	3	MTMFVRKDA4G	1,118.00	MTMFVRKDA4GNP	1,023.60

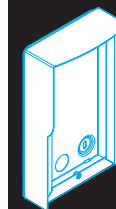

**SURFACE KITS**  
Include rainshield.

### \*DIGITAL VERSION



See page 8  
for MTM VR overview.



See page 28  
for MTM dimensions.

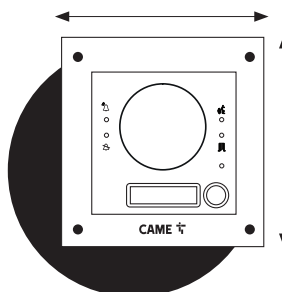

# 4G MTM 4G STANDARD

## ENTRY PANEL WITH KEYPAD



Surface kit shown - includes rainshield

### CONTENTS

- Audio module for 4G System
- Front piece for module with one to ten buttons and keypad
- Frame with two- or three-module profile
- Control module and optional power supply
- Antenna



### SURFACE MOUNTED PANEL KITS

Buttons/Way	Modules	With PSU Kit Code	List Price	Without PSU Kit Code	List Price
1 WAY	2	MTMSKA4G1	892.00	MTMSKA4G1NP	797.60
2 WAY		MTMSKA4G2D	896.00	MTMSKA4G2DNP	801.60
5 WAY	3	MTMSKA4G5	976.00	MTMSKA4G5NP	881.60
10 WAY		MTMSKA4G10D	982.00	MTMSKA4G10DNP	887.60
DIGITAL*		MTMSKDA4G	1,041.00	MTMSKDA4GNP	946.60

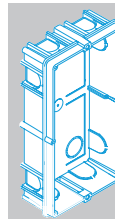

**FLUSH KITS**  
Include back box.

### FLUSH MOUNTED PANEL KITS

Buttons/Way	Modules	With PSU Kit Code	List Price	Without PSU Kit Code	List Price
1 WAY	2	MTMFKA4G1	828.00	MTMFKA4G1NP	733.60
2 WAY		MTMFKA4G2D	831.00	MTMFKA4G2DNP	736.60
5 WAY	3	MTMFKA4G5	901.00	MTMFKA4G5NP	806.60
10 WAY		MTMFKA4G10D	907.00	MTMFKA4G10DNP	812.60
DIGITAL*		MTMFKDA4G	966.00	MTMFKDA4GNP	871.60

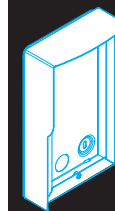

**SURFACE KITS**  
Include rainshield.

**\*DIGITAL VERSION**



See page 8 for MTM overview.



See page 28 for MTM dimensions.

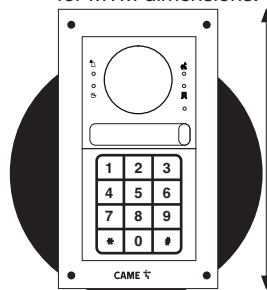



# 4G MTM 4G VR ZAMAK

## ENTRY PANEL WITH KEYPAD



Surface kit shown - includes rainshield

## CONTENTS

- Audio module for 4G System
- Front piece for module with one to ten buttons and keypad
- Frame with two- or three-module profile
- Control module and optional power supply
- Antenna



## SURFACE MOUNTED PANEL KITS

Buttons/Way	Modules	With PSU Kit Code	List Price	Without PSU Kit Code	List Price
1 WAY	2	MTMSVRKA4G1	1,019.00	MTMSVRKA4G1NP	924.60
2 WAY		MTMSVRKA4G2D	1,023.00	MTMSVRKA4G2DNP	928.60
5 WAY	3	MTMSVRKA4G5	1,137.00	MTMSVRKA4G5NP	1,042.60
10 WAY		MTMSVRKA4G10D	1,147.00	MTMSVRKA4G10DNP	1,052.60
DIGITAL*		MTMSVRKA4G	1,193.00	MTMSVRKA4GNP	1,098.60

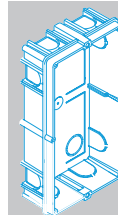

### FLUSH KITS

Include back box.

## FLUSH MOUNTED PANEL KITS

Buttons/Way	Modules	With PSU Kit Code	List Price	Without PSU Kit Code	List Price
1 WAY	2	MTMFVRKA4G1	955.00	MTMFVRKA4G1NP	860.60
2 WAY		MTMFVRKA4G2D	959.00	MTMFVRKA4G2DNP	864.60
5 WAY	3	MTMFVRKA4G5	1,063.00	MTMFVRKA4G5NP	968.60
10 WAY		MTMFVRKA4G10D	1,072.00	MTMFVRKA4G10DNP	977.60
DIGITAL*		MTMFVRKA4G	1,118.00	MTMFVRKA4GNP	1,023.60

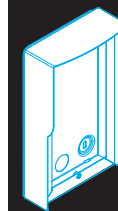

### SURFACE KITS

Include rainshield.

### \*DIGITAL VERSION



See page 8  
for MTM VR overview.



See page 28  
for MTM dimensions.

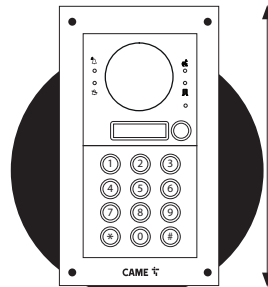

# 4G MTM 4G STANDARD

## ENTRY PANEL WITH PROXIMITY READER HOUSING



Surface kit shown - includes rainshield

### CONTENTS

- Audio module for 4G System
- Front piece for module with one to ten buttons and proximity reader housing\*
- Frame with two- or three-module profile
- Control module and optional power supply
- Antenna



### SURFACE MOUNTED PANEL KITS

Buttons/Way	Modules	With PSU Kit Code	List Price	Without PSU Kit Code	List Price
1 WAY	2	MTMSPA4G1	752.00	MTMSPA4G1NP	657.60
2 WAY		MTMSPA4G2D	755.00	MTMSPA4G2DNP	660.60
5 WAY	3	MTMSPA4G5	852.00	MTMSPA4G5NP	757.60
10 WAY		MTMSPA4G10D	857.00	MTMSPA4G10DNP	762.60
DIGITAL*		MTMSPDA4G	911.00	MTMSPDA4GNP	816.60

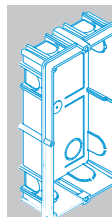

**FLUSH KITS**  
Include back box.

### FLUSH MOUNTED PANEL KITS

Buttons/Way	Modules	With PSU Kit Code	List Price	Without PSU Kit Code	List Price
1 WAY	2	MTMFPA4G1	688.00	MTMFPA4G1NP	593.60
2 WAY		MTMFPA4G2D	691.00	MTMFPA4G2DNP	596.60
5 WAY	3	MTMFPA4G5	776.00	MTMFPA4G5NP	681.60
10 WAY		MTMFPA4G10D	782.00	MTMFPA4G10DNP	687.60
DIGITAL*		MTMFPA4G	837.00	MTMFPA4GNP	742.60

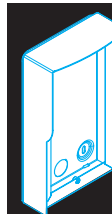

**SURFACE KITS**  
Include rainshield.

\*Reader not included. Accepts most manufacturers panel mount proximity readers.

See page 8 for MTM overview.



See page 28 for MTM dimensions.

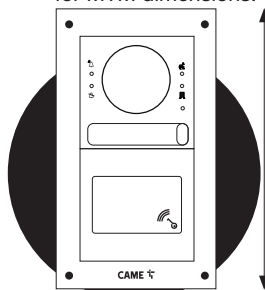

#### \*DIGITAL VERSION



STORES UP TO 3000 NUMBERS!



# 4G MTM 4G VR ZAMAK

## ENTRY PANEL WITH PROXIMITY READER HOUSING



Surface kit shown - includes rainshield

## CONTENTS

- Audio module for 4G System
- Front piece for module with one to ten buttons and proximity reader housing\*
- Frame with two- or three-module profile
- Control module and optional power supply
- Antenna



## SURFACE MOUNTED PANEL KITS

Buttons/Way	Modules	With PSU Kit Code	List Price	Without PSU Kit Code	List Price
1 WAY	2	MTMSVRPA4G1	883.00	MTMSVRPA4G1NP	788.60
2 WAY		MTMSVRPA4G2D	887.00	MTMSVRPA4G2DNP	792.60
5 WAY	3	MTMSVRPA4G5	1,001.00	MTMSVRPA4G5NP	906.60
10 WAY		MTMSVRPA4G10D	1,010.00	MTMSVRPA4G10DNP	915.60
DIGITAL*		MTMSVRPDA4G	1,032.00	MTMSVRPDA4GNP	937.60

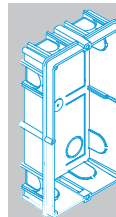

**FLUSH KITS**  
Include back box.

## FLUSH MOUNTED PANEL KITS

Buttons/Way	Modules	With PSU Kit Code	List Price	Without PSU Kit Code	List Price
1 WAY	2	MTMFVRPA4G1	819.00	MTMFVRPA4G1NP	724.60
2 WAY		MTMFVRPA4G2D	822.00	MTMFVRPA4G2DNP	727.60
5 WAY	3	MTMFVRPA4G5	926.00	MTMFVRPA4G5NP	831.60
10 WAY		MTMFVRPA4G10D	936.00	MTMFVRPA4G10DNP	841.60
DIGITAL*		MTMFVRPDA4G	957.00	MTMFVRPDA4GNP	862.60

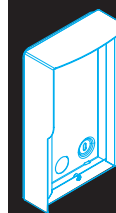

**SURFACE KITS**  
Include rainshield.

\*Reader not included. Accepts most manufacturers panel mount proximity readers.

See page 8  
for MTM VR overview.



See page 28  
for MTM dimensions.

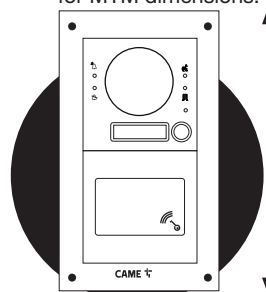

### \*DIGITAL VERSION



# 4G VRW 4G ENTRY PANEL



Surface kit shown - includes rainshield

## CONTENTS

- Audio module for 4G System
- One piece faceplate with one to ten buttons
- Frame with one- or two-module profile
- Control module and optional power supply
- Antenna



## SURFACE MOUNTED PANEL KITS

Buttons/Way	Modules	With PSU Kit Code	List Price	Without PSU Kit Code	List Price
1 WAY	1	VRWSA4G1	769.00	VRWSA4G1NP	674.60
2 WAY		VRWSA4G2D	805.00	VRWSA4G2DNP	710.60
5 WAY	2	VRWSA4G5	856.00	VRWSA4G5NP	761.60
10 WAY		VRWSA4G10D	890.00	VRWSA4G10DNP	795.60
DIGITAL*	3	VRMSKDA4G	1,140.00	VRMSKDA4GNP	1,045.60

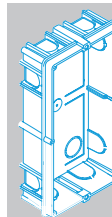

**FLUSH KITS**  
Include back box.

## FLUSH MOUNTED PANEL KITS

Buttons/Way	Modules	With PSU Kit Code	List Price	Without PSU Kit Code	List Price
1 WAY	1	VRWFA4G1	737.00	VRWFA4G1NP	642.60
2 WAY		VRWFA4G2D	773.00	VRWFA4G2DNP	678.60
5 WAY	2	VRWFA4G5	819.00	VRWFA4G5NP	724.60
10 WAY		VRWFA4G10D	853.00	VRWFA4G10DNP	758.60
DIGITAL*	3	VRMFKDA4G	1,099.00	VRMFKDA4GNP	1,004.60

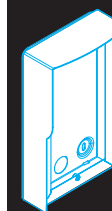

**SURFACE KITS**  
Include rainshield.

### \*DIGITAL VERSION



See page 10 for VRW overview.



See page 30 for VRW dimensions.

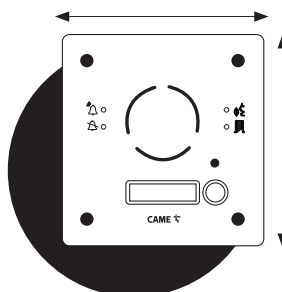



# 4G VRW 4G

## ENTRY PANEL WITH KEYPAD



Surface kit shown - includes rainshield

## CONTENTS

- Audio module for 4G System
- One piece faceplate with one to ten buttons and keypad
- Frame with two- or three-module profile
- Control module and optional power supply
- Antenna



## SURFACE MOUNTED PANEL KITS

Buttons/Way	Modules	With PSU Kit Code	List Price	Without PSU Kit Code	List Price
1 WAY	2	VRWSKA4G1	819.00	VRWSKA4G1NP	724.60
2 WAY		VRWSKA4G2D	842.00	VRWSKA4G2DNP	747.60
5 WAY	3	VRWSKA4G5	897.00	VRWSKA4G5NP	802.60
10 WAY		VRWSKA4G10D	930.00	VRWSKA4G10DNP	835.60
DIGITAL*		VRMSKDA4G	1,140.00	VRMSKDA4GNP	1,045.60

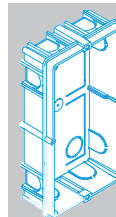

### FLUSH KITS

Include back box.

## FLUSH MOUNTED PANEL KITS

Buttons/Way	Modules	With PSU Kit Code	List Price	Without PSU Kit Code	List Price
1 WAY	2	VRWFK4G1	782.00	VRWFK4G1NP	687.60
2 WAY		VRWFK4G2D	805.00	VRWFK4G2DNP	710.60
5 WAY	3	VRWFK4G5	855.00	VRWFK4G5NP	760.60
10 WAY		VRWFK4G10D	888.00	VRWFK4G10DNP	793.60
DIGITAL*		VRMFKDA4G	1,099.00	VRMFKDA4GNP	1,004.60

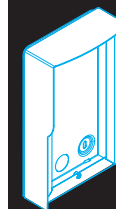

### SURFACE KITS

Include rainshield.

### \*DIGITAL VERSION



See page 10  
for VRW overview.



See page 30  
for VRW dimensions.

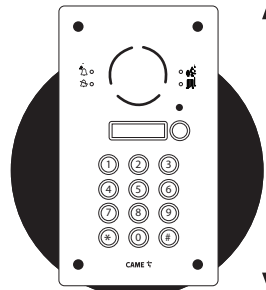

# 4G VRW 4G

## ENTRY PANEL WITH PROXIMITY READER HOUSING



Surface kit shown - includes rainshield

### CONTENTS

- Audio module for 4G System
- One piece faceplate with one to ten buttons and proximity reader housing\*
- Frame with two- or three-module profile
- Control module and optional power supply
- Antenna



### SURFACE MOUNTED PANEL KITS

Buttons/Way	Modules	With PSU Kit Code	List Price	Without PSU Kit Code	List Price
1 WAY	2	VRWSPA4G1	797.00	VRWSPA4G1NP	702.60
2 WAY		VRWSPA4G2D	819.00	VRWSPA4G2DNP	724.60
5 WAY	3	VRWSPA4G5	874.00	VRWSPA4G5NP	779.60
10 WAY		VRWSPA4G10D	908.00	VRWSPA4G10DNP	813.60
DIGITAL*		VRMSPDA4G	1,053.00	VRMSPDA4GNP	958.60

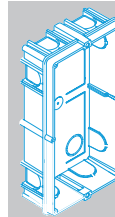

**FLUSH KITS**  
Include back box.

### FLUSH MOUNTED PANEL KITS

Buttons/Way	Modules	With PSU Kit Code	List Price	Without PSU Kit Code	List Price
1 WAY	2	VRWFPA4G1	760.00	VRWFPA4G1NP	665.60
2 WAY		VRWFPA4G2D	782.00	VRWFPA4G2DNP	687.60
5 WAY	3	VRWFPA4G5	833.00	VRWFPA4G5NP	738.60
10 WAY		VRWFPA4G10D	865.00	VRWFPA4G10DNP	770.60
DIGITAL*		VRMFPA4G	1,010.00	VRMFPA4GNP	915.60

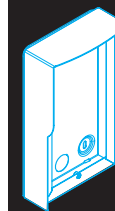

**SURFACE KITS**  
Include rainshield.

\*Reader not included. Accepts most manufacturers panel mount proximity readers.

### \*DIGITAL VERSION



See page 10 for VRW overview.



See page 30 for VRW dimensions.

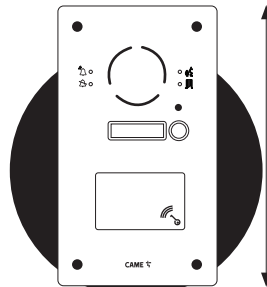





# 4G VRM 4G

## ENTRY PANEL



Surface kit shown - includes rainshield

## CONTENTS

- Audio module for 4G System
- One piece faceplate with one to ten buttons
- Frame with one- or two-module profile
- Control module and optional power supply
- Antenna



## SURFACE MOUNTED PANEL KITS

Buttons/Way	Modules	With PSU Kit Code	List Price	Without PSU Kit Code	List Price
1 WAY	2	VRMSA4G1	793.00	VRMSA4G1NP	698.60
2 WAY		VRMSA4G2	829.00	VRMSA4G2NP	734.60
5 WAY		VRMSA4G5	894.00	VRMSA4G5NP	799.60
10 WAY	3	VRMSA4G10	1,032.00	VRMSA4G10NP	937.60
DIGITAL*		VRMSKDA4G	1,140.00	VRMSKDA4GNP	1,045.60

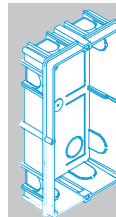

**FLUSH KITS**  
Include back box.

## FLUSH MOUNTED PANEL KITS

Buttons/Way	Modules	With PSU Kit Code	List Price	Without PSU Kit Code	List Price
1 WAY	2	VRMFA4G1	762.00	VRMFA4G1NP	667.60
2 WAY		VRMFA4G2	798.00	VRMFA4G2NP	703.60
5 WAY		VRMFA4G5	863.00	VRMFA4G5NP	768.60
10 WAY	3	VRMFA4G10	994.00	VRMFA4G10NP	899.60
DIGITAL*		VRMFKDA4G	1,099.00	VRMFKDA4GNP	1,004.60

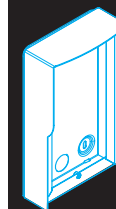

**SURFACE KITS**  
Include rainshield.

### \*DIGITAL VERSION



### LASER ENGRAVING

Customised laser engraving requires up to 5 days lead time (maximum).

See page 10 for VRM overview.



See page 32 for VRM dimensions.

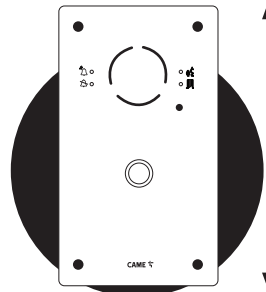

# 4G VRM 4G

## ENTRY PANEL WITH KEYPAD



Surface kit shown - includes rainshield

### CONTENTS

- Audio module for 4G System
- One piece faceplate with one to ten buttons and keypad
- Frame with two- or three-module profile
- Control module and optional power supply
- Antenna



### SURFACE MOUNTED PANEL KITS

Buttons/Way	Modules	With PSU Kit Code	List Price	Without PSU Kit Code	List Price
1 WAY	3	VRMSKA4G1	856.00	VRMSKA4G1NP	761.60
2 WAY		VRMSKA4G2	872.00	VRMSKA4G2NP	777.60
5 WAY		VRMSKA4G5	967.00	VRMSKA4G5NP	872.60
10 WAY	4	VRMSKA4G10	1,248.00	VRMSKA4G10NP	1,153.60
DIGITAL*	3	VRMSKDA4G	1,140.00	VRMSKDA4GNP	1,045.60

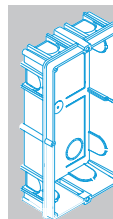

**FLUSH KITS**  
Include back box.

### FLUSH MOUNTED PANEL KITS

Buttons/Way	Modules	With PSU Kit Code	List Price	Without PSU Kit Code	List Price
1 WAY	3	VRMFKA4G1	819.00	VRMFKA4G1NP	724.60
2 WAY		VRMFKA4G2	836.00	VRMFKA4G2NP	741.60
5 WAY		VRMFKA4G5	930.00	VRMFKA4G5NP	835.60
10 WAY	4	VRMFKA4G10	1,206.00	VRMFKA4G10NP	1,111.60
DIGITAL*	3	VRMFKDA4G	1,099.00	VRMFKDA4GNP	1,004.60

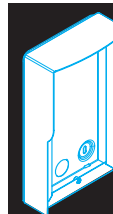

**SURFACE KITS**  
Include rainshield.

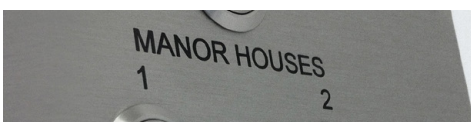

#### LASER ENGRAVING

Customised laser engraving requires up to 5 days lead time (maximum).

See page 10 for VRM overview.



See page 32 for VRM dimensions.

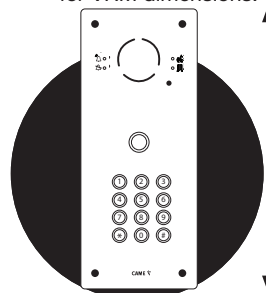

#### \*DIGITAL VERSION





# 4G VRM 4G

## ENTRY PANEL WITH PROXIMITY READER HOUSING



VANDAL RESISTANT

NEW!  
MTM A  
CONNECT  
4G  
LTE  
CONNECT  
COMPATIBLE SYSTEM

ME BPT

Surface kit shown - includes rainshield

## CONTENTS

- Audio module for 4G System
- One piece faceplate with one to ten buttons and proximity reader housing\*
- Frame with two- or three-module profile
- Control module and optional power supply
- Antenna



## SURFACE MOUNTED PANEL KITS

Buttons/Way	Modules	With PSU Kit Code	List Price	Without PSU Kit Code	List Price
1 WAY	3	VRMSPA4G1	834.00	VRMSPA4G1NP	739.60
2 WAY		VRMSPA4G2	850.00	VRMSPA4G2NP	755.60
5 WAY		VRMSPA4G5	945.00	VRMSPA4G5NP	850.60
10 WAY	4	VRMSPA4G10	1,074.00	VRMSPA4G10NP	979.60
DIGITAL*	3	VRMSPDA4G	1,053.00	VRMSPDA4GNP	958.60

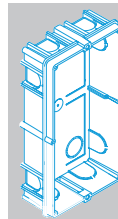

**FLUSH KITS**  
Include back box.

## FLUSH MOUNTED PANEL KITS

Buttons/Way	Modules	With PSU Kit Code	List Price	Without PSU Kit Code	List Price
1 WAY	3	VRMFPA4G1	797.00	VRMFPA4G1NP	702.60
2 WAY		VRMFPA4G2	813.00	VRMFPA4G2NP	718.60
5 WAY		VRMFPA4G5	908.00	VRMFPA4G5NP	813.60
10 WAY	4	VRMFPA4G10	1,032.00	VRMFPA4G10NP	937.60
DIGITAL*	3	VRMFPA4G	1,010.00	VRMFPA4GNP	915.60

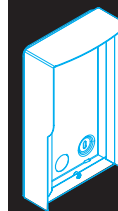

**SURFACE KITS**  
Include rainshield.



### LASER ENGRAVING

Customised laser engraving requires up to 5 days lead time (maximum).

\*Reader not included. Accepts most manufacturers panel mount proximity readers.

See page 10  
for VRM overview.



See page 32  
for VRM dimensions.

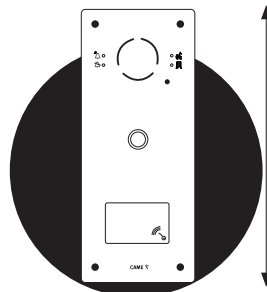

### \*DIGITAL VERSION



STORES  
UP TO  
**3000**  
NUMBERS!

## FLUSH MOUNTING

WITHOUT RAINSHIELD

### 1 MODULE

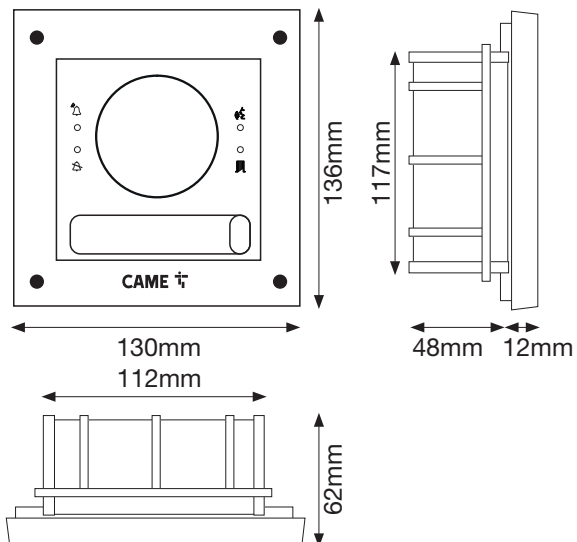

### 2 MODULES

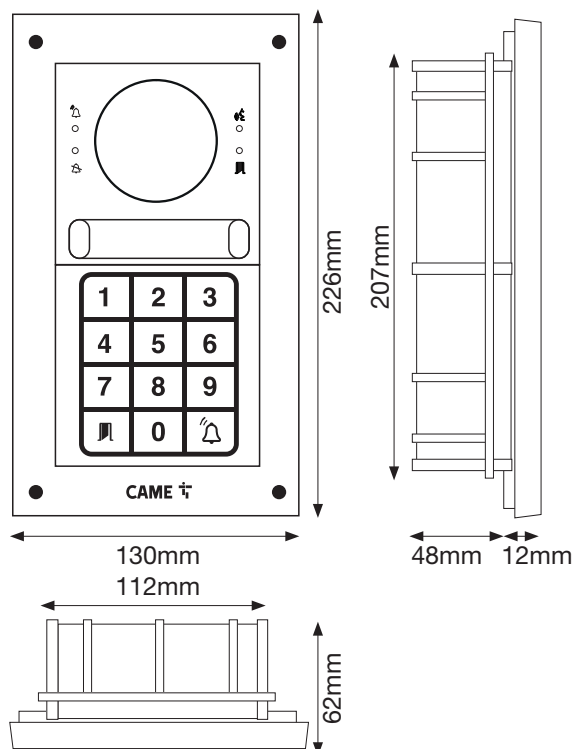

### 3 MODULES

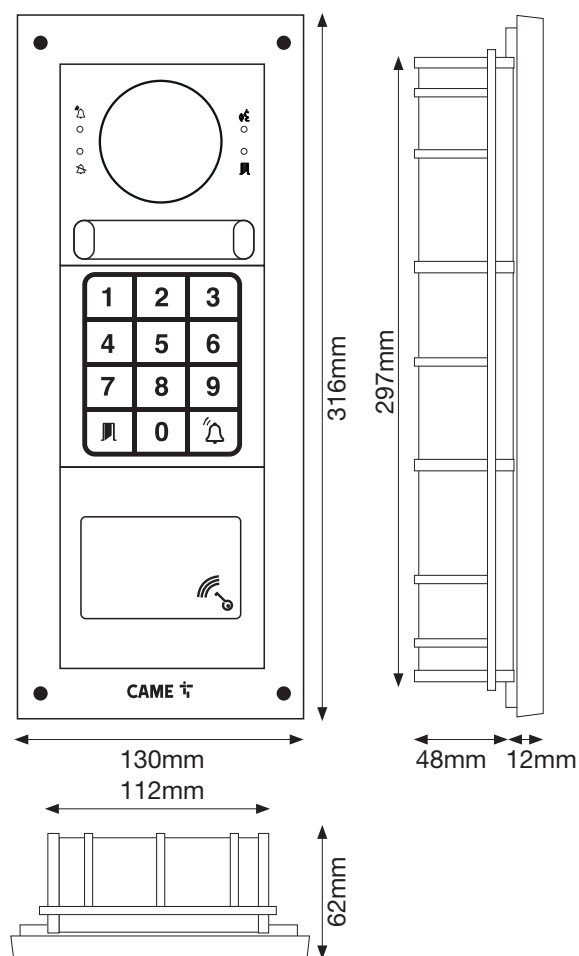

## SURFACE MOUNTING

WITH RAINSHIELD

### 1 MODULE

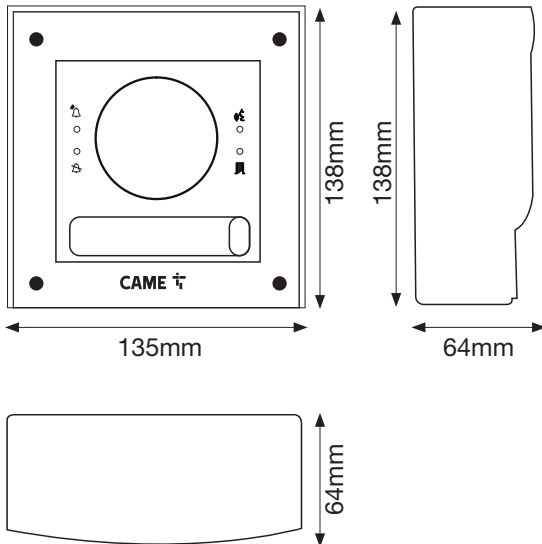

### 2 MODULES

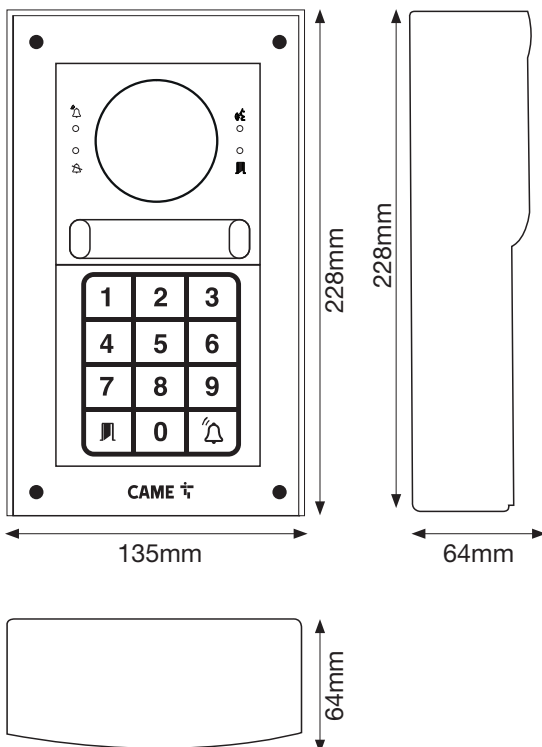

### 3 MODULES

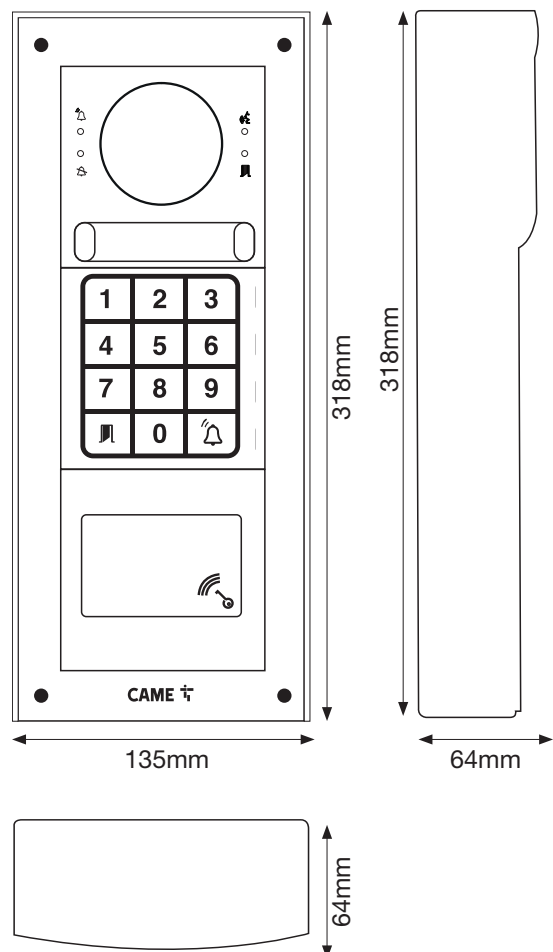

## FLUSH MOUNTING

WITHOUT RAINSHIELD

### 1 MODULE

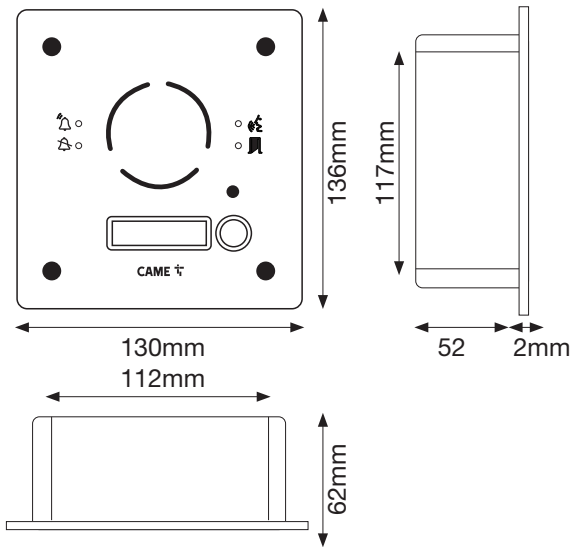

### 2 MODULES

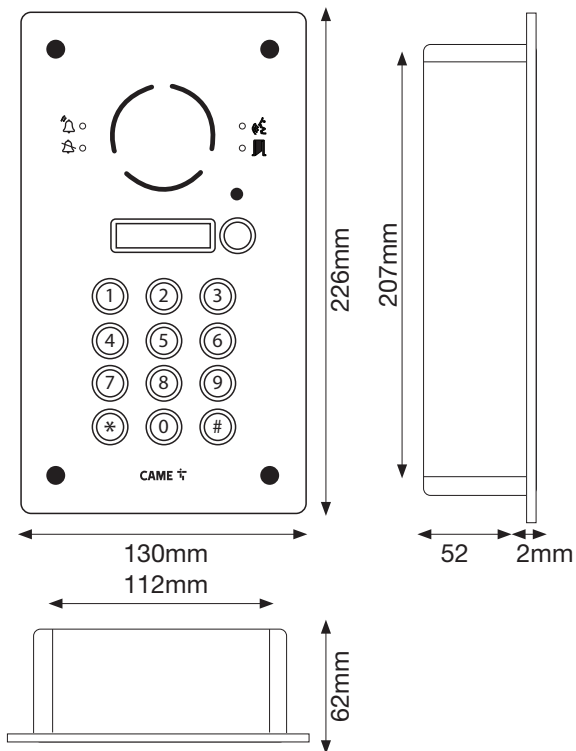

### 3 MODULES

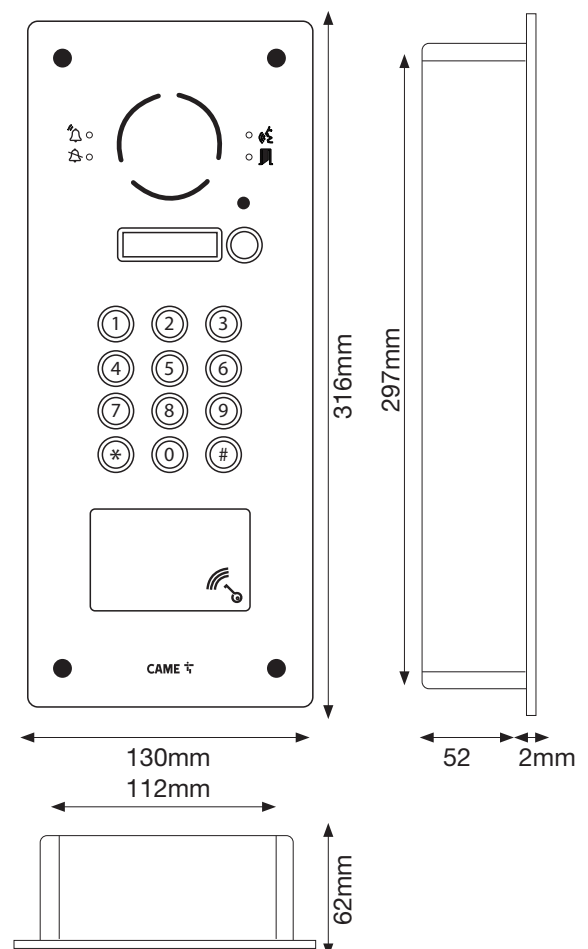

## SURFACE MOUNTING

WITH RAINSHIELD

### 1 MODULE

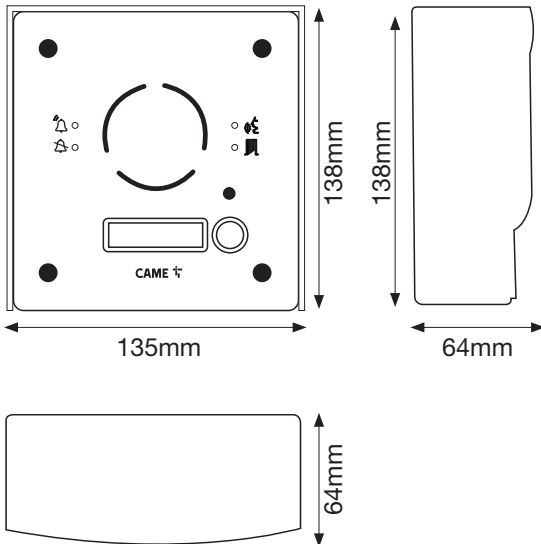

### 2 MODULES

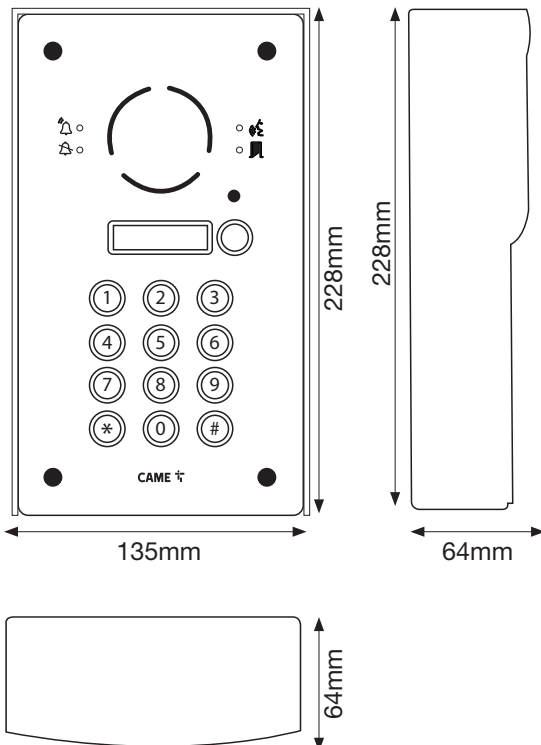

### 3 MODULES

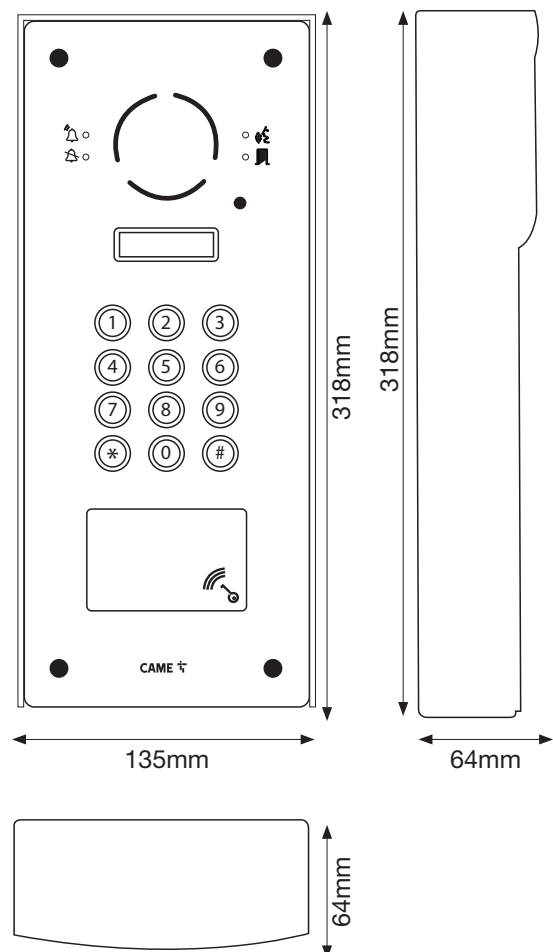

## FLUSH MOUNTING

WITHOUT RAINSHIELD

### 2 MODULES

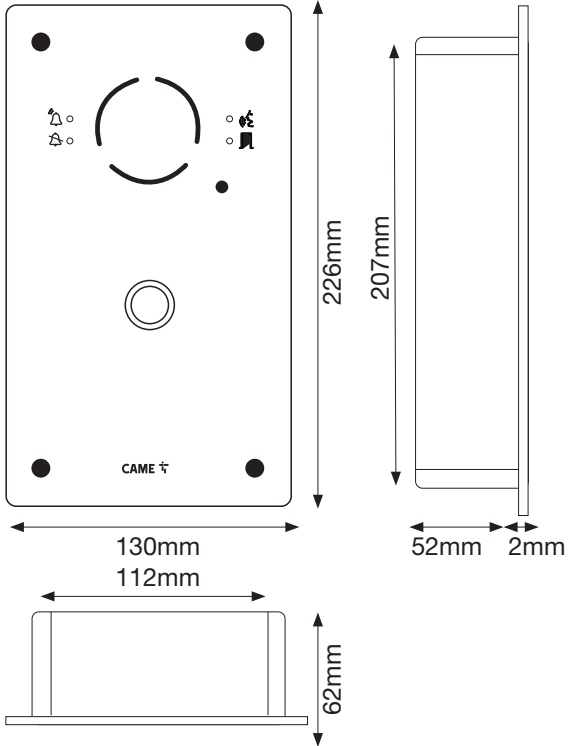

### 4 MODULES

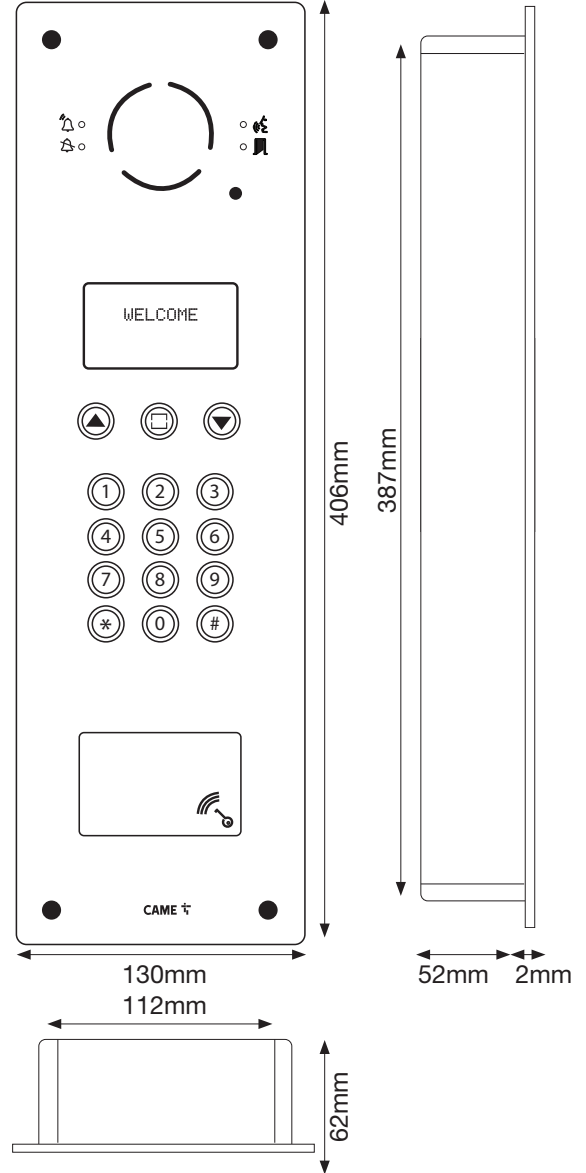

### 3 MODULES

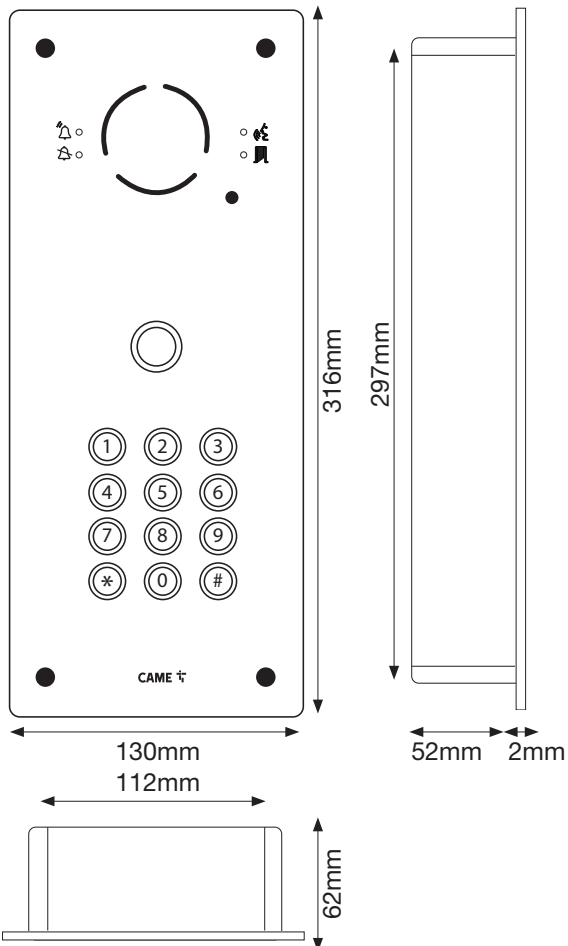



**SURFACE MOUNTING**

WITH RAINSHIELD

**2 MODULES**

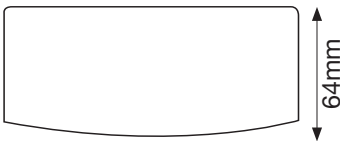
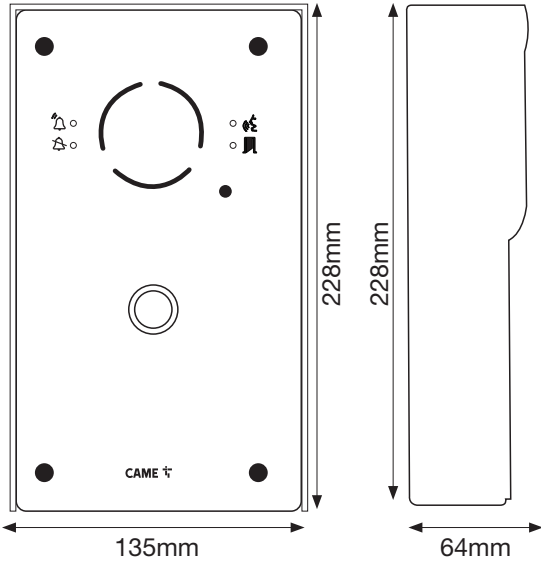

**3 MODULES**

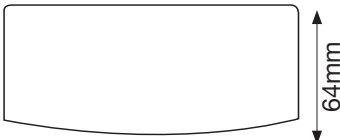
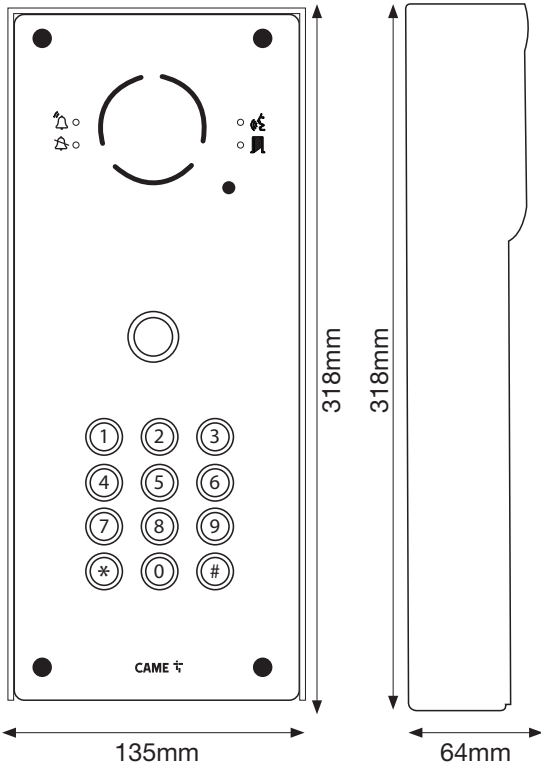

**4 MODULES**

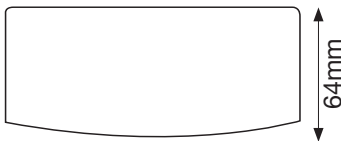
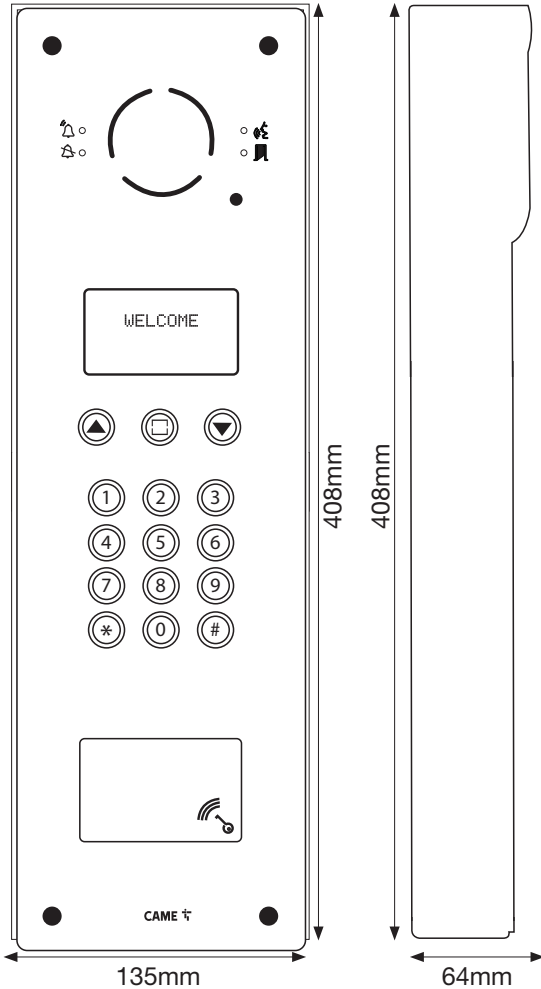

# GENERAL CONDITIONS OF SALE

## CAME UK LTD (“THE SELLER”) / CAME IE LTD (“THE SELLER”)

The Buyer’s attention is drawn in particular to the provisions of clause 10.

### 1. INTERPRETATION

1.1 Definitions. In these Conditions, the following definitions apply:

- Additional Charges:** any additional charges arising under the Contract payable by the Buyer in addition to the price for the Goods and “Additional Charge” shall mean any one of the Additional Charges.
- Buyer:** the person firm or company who buys or agrees to buy the Goods from the Seller.
- Conditions:** these terms and conditions of sale.
- Contract:** the contract between the Seller and the Buyer for the sale and purchase of Goods in accordance with these Conditions.
- Delivery Date:** the date specified by the Seller when the Goods are to be delivered or other such date as may be agreed by the parties in writing;
- Delivery Location:** the location set out in the Order or such other location as the parties may agree in writing, or where no such location is specified, the Buyer’s premises detailed on the quotation given by the Seller to the Buyer in respect of the Goods.
- Force Majeure Event:** as defined in clause 11.1.
- Goods:** all goods (or any part thereof) set out in the Order.
- Group:** in relation to a company, that company, any subsidiary or holding company (as defined in section 1159 of the Companies Act 2006) of that company, and any subsidiary of a holding company of that company.
- Order:** the Buyer’s order for the Goods, as set out in the Buyer’s purchase order form, the Buyer’s written acceptance of the Seller’s quotation, or overleaf, as the case maybe.
- Seller UK:** CAME BPT UK Limited, registered in England and Wales with company number 03267714, whose registered office is Unit 1B, Willow Farm Business Park, Castle Donington, Derby, DE74 2US.
- Seller IE:** CAME BPT IE, registered in Ireland with company number 420195 whose registered office is Unit 9, The Westway Centre, Ballymount, Dublin 12, Ireland.
- Wasted Time Rate:** the charge for wasted time at the Seller’s standard rate for wasted time of £1 (one pound) / €1 (one euro) per minute up to and including 30 (thirty) minutes and thereafter at a charge of £2 (two pounds) / €2 (two euros) per minute, or such other charge as notified to the Buyer from time to time.
- 1.2 Construction. In these Conditions, the following rules apply:
- A person includes a natural person, corporate or unincorporated body (whether or not having separate legal personality).
  - A reference to a party includes its personal representatives, successors or permitted assigns.
  - A reference to a statute or statutory provision is a reference to such statute or provision as amended or re-enacted. A reference to a statute or statutory provision includes any subordinate legislation made under that statute or statutory provision, as amended or re-enacted.
  - Any phrase introduced by the terms including, include, in particular or any similar expression shall be construed as illustrative and shall not limit the sense of the words preceding those terms.
  - A reference to writing or written includes faxes and e-mails.

### 2. BASIS OF CONTRACT

- 2.1 These Conditions shall apply to the sale by the Seller of all Goods purchased by the Buyer and these Conditions shall govern the Contract to the exclusion of any other terms and conditions introduced or submitted by the Buyer.
- 2.2 The Order constitutes an offer by the Buyer to purchase the Goods in accordance with these Conditions. The Buyer is responsible for ensuring that the terms of the Order and any applicable specification of the Goods are complete and accurate.
- 2.3 The Order shall only be deemed to be accepted when the Seller acknowledges the Order in writing and not before, at which point the Contract shall come into existence.
- 2.4 Any tenders or quotations will not constitute an offer. Any tenders or quotations submitted to the Buyer shall remain valid for the period stated therein, but if no period is specified such tenders and quotations shall be valid for 30 days from the date thereof. All tenders and quotations shall be subject to these Conditions.
- 2.5 Any typographical, clerical or other error or omission in any sales literature, quotation, pricelist, acceptance of offer, invoice or other documentation or information issued by the Seller shall be subject to correction without any liability on the part of the Seller.
- 2.6 The Seller’s employees or agents are not authorised to make any representations concerning the Goods unless confirmed by an authorised director of the Seller in writing. In entering into the Contract the Buyer acknowledges that it does not rely on any such representations which are not so confirmed, save that nothing in these Conditions shall exclude the Seller’s liability for fraudulent misrepresentation.
- 2.7 No Order which has been accepted by the Seller may be cancelled by the Buyer except with the agreement in writing of the Seller and on terms that the Buyer shall indemnify the Seller in full against all loss (including loss of profit), costs (including the cost of all labour and materials used), damages, charges and expenses incurred by the Seller as a result of cancellation.

### 3. GOODS

- 3.1 The Goods are described in the Seller’s catalogue as modified by any applicable specification.
- 3.2 Unless the Seller agrees otherwise, only the specifications referred to in the quotation shall form part of the Contract.
- 3.3 The Seller reserves the right subject to giving prior written notice to the Buyer to modify the said specifications where the Goods cannot in the opinion of the Seller be manufactured according to the said specifications and the Buyer agrees to accept the Goods as manufactured according to the specifications so modified in satisfaction of the Seller’s obligations as to manufacture of the Goods under the Contract.
- 3.4 To the extent that the Goods are to be manufactured in accordance with a specification supplied by the Buyer, the Buyer shall indemnify the Seller against all liabilities, costs, expenses, damages and losses (including any direct, indirect or consequential losses, loss of profit, loss of reputation and all interest, penalties and legal and other reasonable professional costs and expenses) suffered or incurred by the Seller in connection with any claim made against the Seller for actual or alleged infringement of a third party’s intellectual property rights arising out of or in connection with the Seller’s use of such specification. This clause 3.2 shall survive termination of the Contract.
- 3.5 The Seller reserves the right to make any changes to the Goods:
- which are required so that the Goods conform with any applicable statutory or EU requirement; or
  - where such changes to the Goods do not materially affect the quality or performance of the Goods.

### 4. SAFETY

- 4.1 Any Goods supplied by the Seller shall be handled correctly by the Buyer and in accordance with any of the Seller’s instructions as notified to the Buyer from time to time. The Buyer must ensure that all appropriate safety precautions are taken and that its staff is aware of and comply with all storage and usage instructions.

### 5. DELIVERY

- 5.1 Unless otherwise agreed by the Seller in writing, the Seller will deliver the Goods to the Delivery Location.
- 5.2 The Seller will reasonably endeavour to deliver the Goods on the Delivery Date, but the time of delivery or performance shall not be of the essence. The Seller shall not be liable for any delay in delivery of the Goods that is caused by a Force Majeure Event or the Buyer’s failure to provide the Seller with adequate delivery instructions or any other instructions that are relevant to the supply of the Goods.
- 5.3 If the Seller fails to deliver the Goods (or any instalment thereof) the Seller’s liability shall be limited to the excess (if any) of the cost to the Buyer (in the cheapest available market) of similar goods to replace those not delivered over the Price of the Goods. The Seller shall have no liability for any failure to deliver the Goods to the extent that such failure is caused by a Force Majeure Event, the Buyer’s fault, or the Buyer’s failure to provide the Seller with adequate instructions in relation to delivery or otherwise.
- 5.4 The Buyer shall provide the Seller with clear delivery instructions and accept delivery on the Delivery Date and at the Delivery Location. Upon delivery the Buyer shall sign a delivery note which will be conclusive evidence that delivery of the Goods has been made.
- 5.5 Unless the Seller agrees otherwise in writing, the Seller shall unload the Goods. The Buyer shall ensure that at least one representative is available to assist the Seller during the unloading of the Goods. Other than by reason of the Seller’s fault, the Buyer shall be charged, as an Additional Charge, for wasted time at the Wasted Time Rate and any other expenses incurred by the Seller for:
- any delay caused by the Buyer’s inability or unwillingness to accept delivery of, or to collect, the Goods; and/or
  - each repeat delivery where the Seller or Seller’s carrier leaves the Delivery Location and subsequently returns to the Delivery Location with the Goods.
- 5.6 If the Buyer fails to accept delivery of the Goods within three Business Days of the Seller notifying the Buyer that the Goods are ready, then, except where such failure or delay is caused by a Force Majeure Event or the Seller’s failure to comply with its obligations under the Contract:
- delivery of the Goods shall be deemed to have been completed at 9.00am on the third working day after the day on which the Seller notified the Buyer that the Goods were ready; and
  - the Seller will store the Goods until delivery takes place, and charge the Buyer for all related costs and expenses (including insurance).
- 5.7 If the Buyer has not accepted delivery of the Goods within 10 working days from day after the Seller notified the Buyer that the Goods were ready for delivery, the Seller may resell or otherwise dispose of part or all of the Goods and, after deducting reasonable storage and selling costs, account to the Buyer for any excess over the price of the Goods or charge the Buyer for any shortfall below the price of the Goods.
- 5.8 The Seller shall have the right to deliver any Goods ordered in instalments. Failure by the Seller to deliver any one or more of the instalments in accordance with these Conditions or any claim by the Buyer in respect of the Goods delivered in any one or more instalments shall not entitle the Buyer either to treat the Contract as a whole as repudiated or to reject or refuse to take delivery of any of the Goods delivered in any other instalment.

### 6. RISK AND TITLE

- 6.1 Risk in the Goods shall pass to the Buyer at the time of delivery, or if the Buyer wrongfully fails to take delivery, the time when delivery is deemed to have taken place in accordance with clause 5.6(a).
- 6.2 Title to the Goods shall not pass to the Buyer until the earlier of:
- the Seller receives payment in full (in cash or cleared funds) for the Goods and any other goods that the Seller has supplied to the Buyer in respect of which payment has become due, in which case title to the Goods shall pass at the time of payment of all such sums; or
  - the Buyer resells the Goods, in which case title to the Goods shall pass to the Buyer at the time specified in clause 6.4.
- 6.3 Until title to the Goods has passed to the Buyer, the Buyer shall:
- store the Goods separately from all other goods held by the Buyer so that they remain readily identifiable as the Seller’s property;
  - not remove, deface or obscure any identifying mark or packaging on or relating to the Goods;
  - maintain the Goods in satisfactory condition and keep them insured against all risks for their full price from the date of delivery;
  - notify the Seller immediately if it becomes subject to any of the events listed in clause 13.1;
  - give the Seller such information relating to the Goods as the Seller may require from time to time; and
  - not pledge or in any way charge by way of security for any indebtedness any of the Goods.
- 6.4 Subject to clause 6.5, the Buyer may resell or use the Goods in the ordinary course of its business (but not otherwise) before the Seller receives payment for the Goods. However, if the Buyer resells the Goods before that time:
- it does so as principal and not as the Seller’s agent; and
  - title to the Goods shall pass from the Seller to the Buyer immediately before the time at which resale by the Buyer occurs.
- 6.5 If before title to the Goods passes to the Buyer the Buyer becomes subject to any of the events listed in clause 13.1, then, without limiting any other right or remedy the Seller may have:
- the Buyer’s right to resell the Goods or use them in the ordinary course of its business ceases immediately; and
  - the Seller may at any time:
    - require the Buyer to deliver up all Goods in its possession which have not been resold, or irrevocably incorporated into another product; and
    - if the Buyer fails to do so promptly, enter any premises of the Buyer or of any third party where the Goods are stored in order to recover them.

## 7. PRICE

- 7.1 The price for the Goods shall be the price specified by the Seller in the quotation or, if no price is quoted, the price set out in the Seller's published price list in force as at the date of delivery.
- 7.2 Unless otherwise agreed in writing, the price of the Goods is exclusive of the costs and charges of packaging, insurance and transport of the Goods, which shall be invoiced to the Buyer as an Additional Charge.
- 7.3 The price of the Goods and any Additional Charges are exclusive of amounts in respect of value added tax (VAT). The Buyer shall, on receipt of a valid VAT invoice from the Seller, pay to the Seller such additional amounts in respect of VAT as are chargeable on the supply of the Goods.
- 7.4 List Prices shown in this price list are displayed in (£) for UK and (€) for Ireland.
- 7.5 The Seller may, by giving notice to the Buyer at any time before delivery, increase the price of the Goods to reflect any increase in the cost of the Goods that is due to:
- (a) any factor beyond the Seller's control (including foreign exchange fluctuations, increases in taxes and duties, and increases in labour, materials and other manufacturing costs);
  - (b) any request by the Buyer to change the delivery date(s), quantities or types of Goods ordered, or the Specification; or
  - (c) any delay caused by any instructions of the Buyer or failure of the Buyer to give the Seller adequate or accurate information or instructions.

## 8. PAYMENT

- 8.1 The Seller shall be entitled to invoice the Buyer for price of the Goods and any Additional Charges on or at any time before dispatch of the Goods or any instalment thereof. In the event that any Additional Charges arise following the issue by the Seller of the invoice, the Seller shall be entitled to invoice the Buyer as and when the Additional Charges arise.
- 8.2 Unless otherwise agreed in writing, the Buyer shall pay the invoice in full and in cleared funds by the date specified in the invoice or where no date or time frame is specified within 30 calendar days of the date of the invoice. Payment shall be made to the bank account nominated in writing by the Seller. Time of payment is of the essence.
- 8.3 The Buyer shall make payment for the price of the Goods in Sterling (euros) unless agreed otherwise in writing. Any payment received by the Seller in any other currency will not be deemed to be payment for the Goods in question. Where the Buyer makes payment for the Goods by cheque the Seller reserves the right to charge a surcharge of £10.00 in the event that any cheque rendered in payment of the Seller's invoices initially refused.
- 8.4 If the Buyer fails to make payment due to the Seller under the Contract by the due date for payment then, without prejudice to any other right or remedy available to the Seller:
- (a) all invoices issued to the Buyer by the Seller in respect of any Goods sold or supplied pursuant to the Contract or any goods sold or supplied pursuant to any other contract shall immediately fall due for payment;
  - (b) any credit, settlement terms, supply of goods or discount rates offered or extended by the Seller to the Buyer in respect of the same shall be cancelled immediately;
  - (c) the Buyer shall pay interest on the overdue amount at the rate of 10% per annum above Seller's bank's base rate from time to time. Such interest shall accrue on a daily basis from the due date until actual payment of the overdue amount, whether before or after judgment. The Buyer shall pay the interest together with the overdue amount; and
  - (d) the Seller shall be entitled to suspend any further deliveries of any Goods or goods agreed to be sold by the Seller to the Buyer or any instalment thereof (being the subject of the Contract or any other contract).
- 8.5 The Buyer shall pay all amounts due under the Contract in full without any set-off, counterclaim, deduction or withholding (except for any deduction or withholding required by law). The Seller may at any time, without limiting any other rights or remedies it may have, set off any amount owing to it by the Buyer against any amount payable by the Seller to the Buyer.

## 9. WARRANTY

- 9.1 The Seller warrants that:
- (a) the Goods will correspond with the Seller's specification for them on delivery;
  - (b) the Goods (except those wear items that are listed in the Seller's guide entitled "Operations Guide Relating to the Goods" as notified to the Buyer and as amended from time to time) manufactured by the Seller or its Group, will be free from material defects for 3 years from the Delivery Date; and
  - (c) where the seller is supplying goods from other manufacturers; their standard recommended warranty will apply.
- 9.2 Subject to clause 9.3, if:
- (a) the Buyer gives notice in writing to the Seller immediately on discovery but in any event within 14 days of discovery that some or all of the Goods do not comply with the warranty set out in clause 9.1;
  - (b) the Seller is given a reasonable opportunity of examining such Goods; and
  - (c) the Buyer (if asked to do so by the Seller) returns such Goods to the Seller's place of business at the Buyer's cost, the Seller shall, at its option, repair or replace the defective Goods, or refund the price of the defective Goods in full.
- 9.3 The Seller shall not be liable for Goods' failure to comply with the warranty set out in clause 9.1 in any of the following events:
- (a) the Buyer makes any further use of such Goods after giving notice in accordance with clause 9.2;
  - (b) the defect arises because the Buyer failed to follow the Seller's oral or written instructions as to the storage, commissioning, installation, use and maintenance of the Goods or (if there are none) good trade practice regarding the same;
  - (c) the defect arises as a result of the Seller following any drawing, design or Specification supplied by the Buyer;
  - (d) the Buyer alters or repairs such Goods without the written consent of the Seller;
  - (e) the defect arises as a result of fair wear and tear, wilful damage, negligence, or abnormal storage or working conditions; or
  - (f) the Goods differ from their description specification as a result of changes made to ensure they comply with applicable statutory or regulatory requirements.
- 9.4 Except as provided in this clause 9, the Seller shall have no liability to the Buyer in respect of the Goods' failure to comply with the warranty set out in clause 9.
- 9.5 The terms implied by sections 13 to 15 of the Sale of Goods Act 1979 are, to the fullest extent permitted by law, excluded from the Contract.
- 9.6 These Conditions shall apply to any repaired or replacement Goods supplied by the Seller.

## 10. LIABILITY

- 10.1 Nothing in these Conditions shall limit or exclude the Seller's liability for:
- (a) death or personal injury caused by its negligence, or the negligence of its employees, agents or subcontractors (as applicable);
  - (b) fraud or fraudulent misrepresentation;
  - (c) breach of the terms implied by section 12 of the Sale of Goods Act 1979;
  - (d) defective products under the Consumer Protection Act 1987; or

- (e) any matter in respect of which it would be unlawful for the Seller to exclude or restrict liability.

## 10.2 Subject to clause 10.1:

- (a) the Seller shall under no circumstances whatever be liable to the Buyer, whether in contract, tort (including negligence), breach of statutory duty, or otherwise, for any loss of profit, goodwill or any indirect or consequential loss arising under or in connection with the Contract; and
- (b) the Seller's total liability to the Buyer in respect of all other losses arising under or in connection with the Contract, whether in contract, tort (including negligence), breach of statutory duty, or otherwise, shall in no circumstances exceed 100% of price of the Goods.

## 11. FORCE MAJEURE

- 11.1 The Seller shall not be liable to the Buyer nor be deemed to be in breach of Contract by reason of any delay in performing, or any failure to perform, any of the Seller's obligations in relation to the Contract if the delay or failure was due to a Force Majeure Event. The following shall (without limitation) be regarded as Force Majeure Event:
- (a) act of God, explosion, flood, tempest, fire or accident;
  - (b) war or threat of war, sabotage, insurrection, terrorism, civil disturbance or requisition;
  - (c) acts, restrictions, regulations, bye-laws, prohibitions or measures of any kind on the part of any governmental, parliamentary or local authority;
  - (d) import or export regulations or embargoes;
  - (e) strikes, lock-outs or other industrial actions or trade disputes (whether involving employees of the Seller or of a third party);
  - (f) difficulties in obtaining raw materials, labour, fuel, parts or machinery; and
  - (g) power failure or breakdown in machinery.

## 12. INTELLECTUAL PROPERTY

- 12.1 All specifications, drawings, designs and technical description, and all documents and information and "know-how" whatsoever supplied by the Seller to the Buyer is as between the Seller and the Buyer the Seller's intellectual property and shall at all times be treated by the Buyer as confidential and shall not without the prior written consent of the Seller be used by the Buyer except for the purposes of the Contract.
- 12.2 The Buyer will indemnify the Seller against all actions claims demands costs charges, penalties, royalties and expenses arising directly or indirectly or incurred by reason of any infringement or alleged infringement of or any right attributable to any letters patent, registered design trade mark, trade name, copyright or proprietary right arising from the use of any instructions, specifications or designs whether express or implied supplied by the Buyer to the Seller.

## 13. INSOLVENCY OF BUYER

- 13.1 This Condition applies if:
- (a) the Buyer makes any voluntary arrangement with its creditors or (being an individual or firm) becomes bankrupt or (being a company) becomes subject to an administration order or goes into liquidation (otherwise than for the purposes of amalgamation or reconstruction); or
  - (b) an encumbrancer takes possession or a receiver is appointed, of any of the property or assets of the Buyer; or
  - (c) the Buyer ceases, or threatens to cease, to carry on business; or
  - (d) the Seller reasonably apprehends that any of the events mentioned above is about to occur in relation to the Buyer and notifies the Buyer accordingly.
- 13.2 If this Condition applies then, without prejudice to any other right or remedy available to the Seller, the Seller shall be entitled to terminate the Contract with immediate effect by giving written notice to the Buyer and/or suspend any further deliveries under the Contract without any liability to the Buyer, and if the Goods have been delivered but not paid for, all of the Seller's outstanding invoices to the Buyer become immediately due and payable notwithstanding any previous agreement or arrangement to the contrary.
- 13.3 Termination of the Contract, however arising, shall not affect any of the parties' rights, remedies, obligations and liabilities that have accrued as at termination.

## 14. GENERAL

- 14.1 Notices. Any notice required or permitted to be given by either party to the other under these Conditions shall be in writing addressed to that other party at his registered office or principal place of business or such other address as may at the relevant time have been notified pursuant to this provision to the party giving the notice.
- 14.2 Severance. If any provision of these Conditions is held by any competent authority to be invalid or unenforceable in whole or in part the validity of the other provisions of these Conditions shall remain in full force and effect.
- 14.3 Waiver. No waiver by the Seller of any breach of the Contract by the Buyer shall be considered as a waiver of any subsequent breach of the same or any other provision.
- 14.4 Third party rights. A person who is not a party to the Contract shall not have any rights to enforce its terms.
- 14.5 Variation. No variation of these Conditions may be given by any of the Seller's employees unless confirmed in writing by an authorised director of the Seller and no collateral or supplemental contract may be made or construed unless confirmed in writing by an authorised director of the Seller on the Seller's official stationery.
- 14.6 Entire Agreement. The Buyer acknowledges that it has not relied on any statement, promise, representation, assurance or warranty made or given by or on behalf of the Seller which is not set out in the Contract.
- 14.7 Governing law and jurisdiction. The Contract shall be governed by the laws of England, and the Buyer agrees to submit to the non-exclusive jurisdiction of the English courts.

## 15. SPECIFICATIONS AND INSTRUCTIONS

- 15.1 Unless the Seller agrees otherwise, only the specifications referred to in the quotation shall form part of the Contract.
- 15.2 The Seller reserves the right subject to giving prior written notice to the Buyer to modify the said specifications where the Goods cannot in the opinion of the Seller be manufactured according to the said specifications and the Buyer agrees to accept the Goods as manufactured according to the specifications so modified in satisfaction of the Seller's obligations as to manufacture of the Goods under the contracts.
- 15.3 App Based Goods – the Buyer shall ensure that prior to supplying any app based goods to any customer it shall include within its customer terms and conditions for supply of the App based Goods a requirement for the customer to have read, understood and agreed to the app terms and conditions for the Goods prior to completion of purchase of the Goods. Where such Goods are supplied or installed by a third party for and/or on behalf of the Buyer the Buyer shall ensure that such installer also complies with this clause 10.3 by including this provision in its contract with the installer.

## WATCH THE FULL **MTM A CONNECT** VIDEO

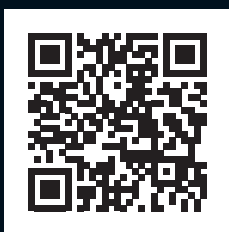

[WWW.CAME.COM/UK/MTMACONNECT](http://WWW.CAME.COM/UK/MTMACONNECT)  
OR SCAN THE QR CODE

### **CAME UK - South**

Liberta House Maxted Road  
Maylands Ind. Est.  
Hemel Hempstead  
Herts  
HP2 7DX

**Tel:** 01442 230 800

All list prices are GBP (£) excluding VAT.

### **CAME UK - North**

Unit 1B  
Sills Road  
Willow Farm Business Park  
Castle Donington  
DE74 2US

**Tel:** 0115 921 0430

### **CAME - Ireland**

Unit 9  
The Westway Centre  
Ballymount  
Dublin 12  
D12 P973

**Tel:** +353 (0)1 450 7442

All list prices are IE (€) excluding VAT.



© CAME UK - MTM4GKITS0724 - 2024 - EN UK  
CAME RESERVES THE RIGHT TO MAKE ANY CHANGES TO THIS DOCUMENT AT ANY TIME.  
YOU MAY NOT EVEN PARTIALLY REPRODUCE THIS DOCUMENT.



**CAME S.p.A.**  
is has the following Quality, Environmental  
and Safety certifications:  
**ISO 9001**  
**ISO 14001**  
**ISO 45001**